

THE
 **HEATSTORE**

Aqua-Plus

SHOWER
HANDBOOK

IMPORTANT :

This booklet should be given to the customer after installation and demonstration

Thank you for choosing a quality "Heatstore" product manufactured in England

diagram 1

Contents

Information for the user	page
How to Use your "Aqua-Plus" Shower	2
How the "Aqua-Plus" Shower Works	4
What to do if Things Go Wrong	6
How to Maintain your "Aqua-Plus" Shower	11
Additional Accessories	11
Information for the installer	
Fixing shower to the wall	7
Plumbing.....	9
Electrical	10
Guarantee	12

How to use your "Aqua-Plus" Shower

1. Ensure the electricity and water is turned on to the unit.
2. Your shower has 3 power settings selected by turning knob "A". The most popular is "HIGH" indicated by "red●" and for your convenience this can be obtained in 2 positions so you are always only one step away from maximum power. There are also options for a "LOW" or "COLD" shower (see notes 8 and 9).
For this example turn knob "A" to "HIGH" (either "red ●" will do) and set knob "C" to position 5 on the temperature scale.
3. **Press button "B"**. The water will flow and 3 lights will illuminate to indicate that the selected power rating is "HIGH" (indicated by "red●" next to the lights).
4. **Allow about 20 seconds** for the temperature of the water to stabilise.
- 5a If the water is **too hot** then increase the flow of water by **turning knob "C" clockwise** to position 4 on the temperature

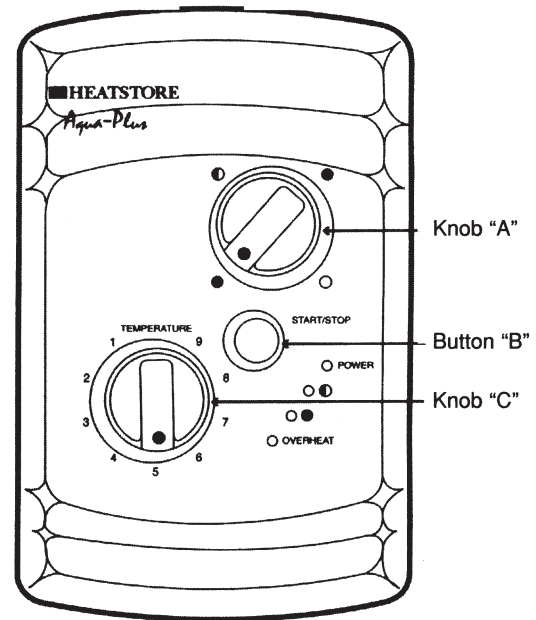

- control scale. **Wait 20 seconds** for the temperature of the water to stabilise. Repeat turning clockwise if necessary until you get the water temperature of your liking.
- 5b If the water is **too cold, turn knob “C” anti-clockwise** to position 6 in the temperature control scale and continue as necessary until you get the water temperature of your liking. The final adjustment may be anywhere on the scale.
 - 5c Basically turning knob “C” **anti-clockwise increases** the water temperature, whilst turning **clockwise decreases** the water temperature.
 6. Once a temperature setting to your liking has been achieved knob “C” will rarely need adjusting, eg: adjust for variations of incoming mains water temperature between summer and winter.
 7. When you have **finished** showering push **button “B” only**. You have no need to adjust knobs “A” or “C”. Switch off the electricity at the ceiling switch or local isolator, where fitted.
 8. The “LOW ●” setting knob “A” reduces the power used by the shower giving a cooler shower or the option of reduced water flow. This option is mainly for Summer usage and if this is used then knob “C” must be re-adjusted. On this setting 2 lights will illuminate to indicate that the selected power rating is “LOW ●”.
 9. The “COLD” setting indicated by “grey o” of knob “A” will supply water without any heating, and only 1 light will illuminate to indicate this.
 10. Your shower is **designed to stabilise temperature** changes caused by water pressure fluctuations. These can result from toilets being flushed or taps being turned on and off. When this happens your showering temperature will be held within a controlled band, provided that the minimum pressure required by the shower is maintained.
 11. Your shower requires a minimum operating pressure of 69kPa (0,7 Bar, 10p.s.i.). At pressures above 69kPa (0,7 Bar, 10p.s.i.) it will minimise temperature fluctuations as detailed in note 10. If the water pressure falls below 69kPa (0,7 Bar, 10p.s.i.) it is likely that the pressure switch will turn off the power to the heating elements, resulting in a cold shower. The two middle power indication lights will flicker and go out and the “OVERHEAT” light may come on to indicate that this has happened.
 12. During normal operation if an overheated water temperature is sensed by the shower then the thermal cut-out will switch off the heating elements. The “OVERHEAT” light will illuminate to provide a visual indication that this has taken place. Water will continue to flow and as the water temperature falls the heating elements will be turned back on. If the “OVERHEAT” light continues to cycle then increase the water flow rate by turning knob “C” clockwise and check that the handset does not require de-scaling. If the “OVERHEAT” light still continues to cycle then turn knob “A” to the “LOW ●” power setting (knob “C” will need adjusting). If the shower is operated after it has recently been used the “OVERHEAT” light may illuminate for a few seconds. This indicates that there is still some hot water left in the shower. Either, wait a few moments for the light to go out or turn knob “C” clockwise.

13. Note that knob "C" IS NOT A TAP and does not turn the water off.

WARNING! DO NOT SWITCH THE SHOWER ON IF YOU SUSPECT IT OF BEING FROZEN. WAIT UNTIL YOU ARE SURE IT HAS THAWED OUT.

diagram 2

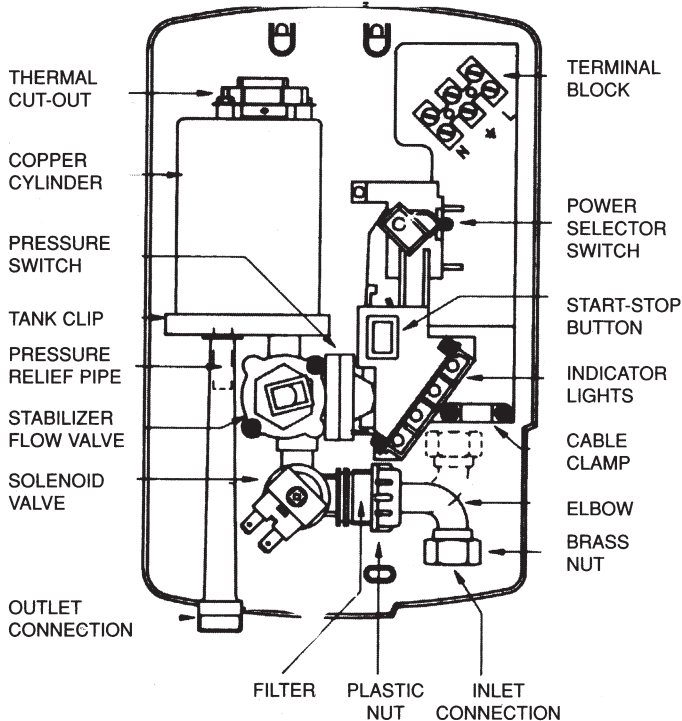

How your "Aqua-Plus" Shower Works

Your shower is designed for convenience, economy and Safety of use.

- 1 Water is heated instantaneously as it flows over the heating elements in the copper cylinder (diagram 2).
- 2 The required water temperature is achieved by adjusting the rate of water flow. Diagram 3 shows the principle involved in relating temperature rise to flow rate. The higher the water flow the lower the temperature rise, and vice versa. The temperature of the water supplied from the mains can vary considerably throughout the year from 5 to 20°C. This means that in Winter, the flow rate will be less than in the Summer to achieve the same outlet temperature. In Summer the "LOW" power setting may give adequate hot water.
- 3 The heaters are only switched on when sufficient water is flowing. This is done automatically with a switch which works on water pressure and is indicated by 2 or 3 lights illuminating depending on knob "A" power selection.
- 4 The water is turned on and off by the solenoid valve built into the shower. This is switched on by button "B".
- 5 The flow of water is automatically held at the level set by the user even though the supply pressure may vary (see "How to use your shower" note 10).

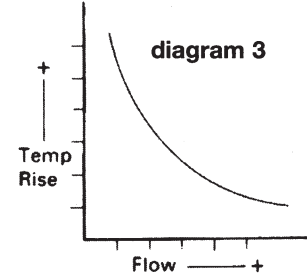
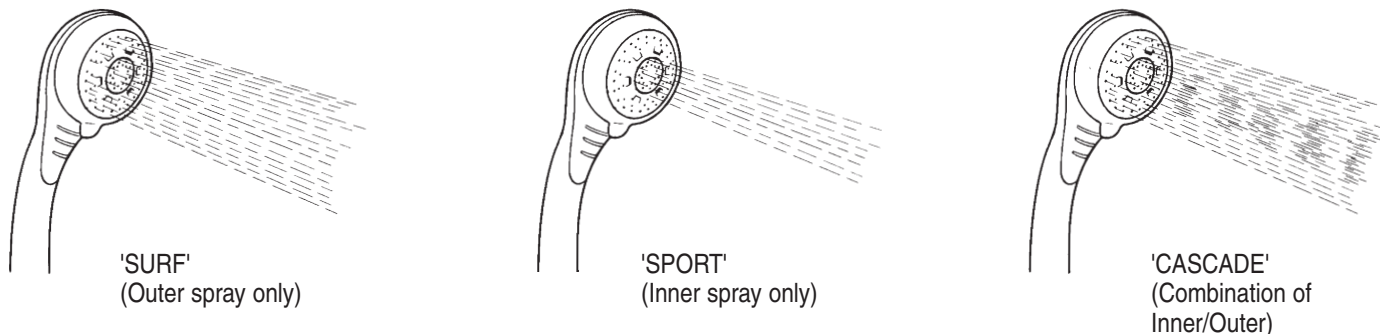

Diagram 4



- 6 If the water supply falls below a set limit, the pressure switch will operate and switch off the power to the elements. This is indicated by the middle power setting lights flickering and going out (see “How to use your shower” note 11).
- 7 As a further safeguard, a thermal cut-out switches the power off if the water temperature climbs above a set limit and the “OVERHEAT” light will come on. This cut-out which gives an audible click, may also operate due to residual heat when the shower is switched off. It will reset itself if cold water is run through the shower for 10 to 20 seconds, and the “OVERHEAT” light will go out.

- 8 The pressure relief device is to safeguard against extreme abuse conditions.
- 9 There are 3 defined spray plate settings adjustable by rotating the spray plate (see diagram 4). If desired many combinations between the 3 can be achieved.



The Shower Head rotates through approximately 140°.

IN ORDER TO MAINTAIN THE PERFORMANCE OF YOUR SHOWER YOU MUST CLEAN THE SHOWERHEAD. USE KEY PROVIDED TO REMOVE SPRAY PLATE.

What to Do if Things Go Wrong

SELF HELP

If the shower is unsatisfactory, make the following checks before calling out the contractor. Any one of these adjustments could restore the performance

a) Water too HOT	Increase water flow by adjusting the temperature control clockwise. Clean handset. Select different spray pattern. Switch power to "LOW ●" setting. Increase pressure of water supply e.g. fully open service valve or stop cock. Check hose is not kinked restricting the water flow.
b) Water too COLD	Decrease water flow by adjusting the temperature control anti-clockwise. Select different spray pattern. Switch power to "HIGH ●" setting
c) Spray Pattern poor	Clean spray plate and flush heater. Select different spray pattern.
d) Water takes longer to heat up	Thermal cut-out has operated after previous use ("OVERHEAT" light is on). Switch power to "HIGH ●" setting
e) Water goes cold while using shower	Check power setting lights are on. Check water pressure has not fallen so far as to let pressure switch cut-out, e.g. another tap drawing water off, indicated by "LOW PRESSURE" light on. Raise position of handset.
f) Broken parts	We have a comprehensive spares list. Fitting instructions are provided with spares.

PROFESSIONAL SERVICE

If the previous checks fail to restore the performance, you should seek professional help.

The person who installed the shower is probably the best one to repair it and is certainly the person to contact if you have a problem in the guarantee period.

The following additional checklist is provided for the benefit of the qualified serviceman.

WARNING: SWITCH OFF THE ELECTRICITY AT THE ISOLATING SWITCH BEFORE REMOVING THE COVER TO MAKE CHECKS.

a) Water too HOT	Water flow restricted by blockage in filter of solenoid valve. Switch off water and undo plastic nut on elbow, loosen brass nut to swing elbow away from solenoid. Remove filter in solenoid with long nosed pliers and flush clean.
b) Water too COLD	Check circuit through thermal cut-out. Check circuit through microswitches on the pressure switch. Check each element circuit. Check tightness of electrical connections.
c) No control over water flow	Undo headworks of stabiliser valve. Check stabiliser is in place and remove any debris in valve.
d) Water leaks from burst pressure relief valve	Check for cause of high pressure and remove it. Blockage on outlet i.e: blocked spray plate. Replace the pressure relief disc.
e) Water does not flow when button "B" is pressed	Check circuit through solenoid coil. Check circuit through microswitches. If defective, then replace. Power supply not reaching shower.

Heatstore After Sales Service

We offer a technical advisory service on the telephone to contractors and other customers with problems in the field.

RING 08709 000430

And ask for the "HEATSTORE SHOWER HOTLINE".
Spare parts can be supplied against most CREDIT or DEBIT cards.

Remember to quote the exact type of shower, as written on the front of the shower and on this leaflet. It may also be of use to have a note of the Catalogue number as stated on the rating plate inside the shower.
(See diagram 5 for location).

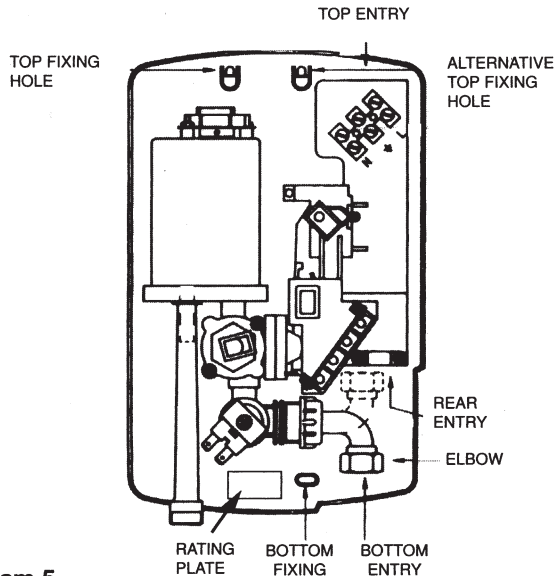

diagram 5

Installation Instructions

ALL WIRING AND INSTALLATION MUST BE SUPERVISED BY A QUALIFIED ELECTRICIAN.

WARNING! DO NOT INSTALL THIS SHOWER IN A ROOM WHERE IT MAY BE SUBJECT TO FREEZING

We recommend that the installation is done in the following sequence.

- (a) Fixing the shower to the wall
- (b) Plumbing
- (c) Electrical connections

(a) Fixing the shower to the wall

1. Position the riser rail at the height recommended in diagram 6 and mark its position.
2. Position the heater so that the sides of the unit are vertical and the top is level with, **or up to 0.6 metres (2ft) maximum below the top of the riser rail**. Choose a flat piece of wall to avoid the possibility of distorting the backplate thus making the front cover a poor fit.
3. Adjust the positions to get the most convenient arrangement taking the following into account.
 - (a) The possible need to use the handset over a sink for hairwashing etc.
 - (b) The heater must not be mounted in the direct spray from the handset.
 - (c) The handset must not be able to come into contact with used water in the cubicle, bath or basin. If it can, even after the hose has been retained by the soap dish (see diagram 11),

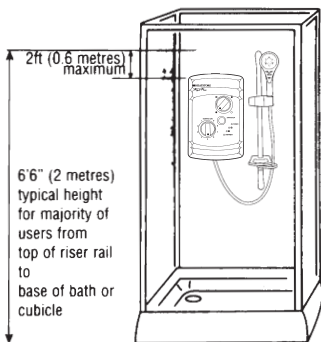

then a vacuum breaker must be fitted. It should be noted that these devices are liable to minor leakage so they must be positioned so that any drips are not detrimental.

4. Fix the riser rail with screws provided. The fixing holes at the base of the brackets will be disclosed by removing the plastic fronts. Assemble as shown in diagram 11.

5. Decide the position of the electrical cable to the unit. If top or bottom entry is chosen (according to diagram 5), cut away the walls of the backplate as shown in diagram 7.

6. Decide the position of entry of the cold water pipe into the unit. If rear, please read the section on plumbing. If bottom, remove the front cover (complete knobs) and cut away the detachable corner section as shown.



Diagram 6

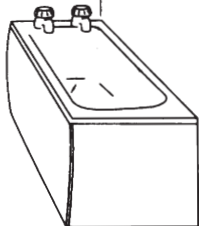
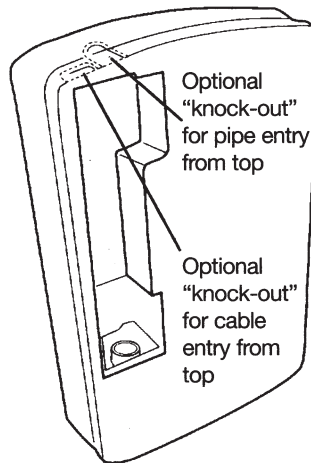
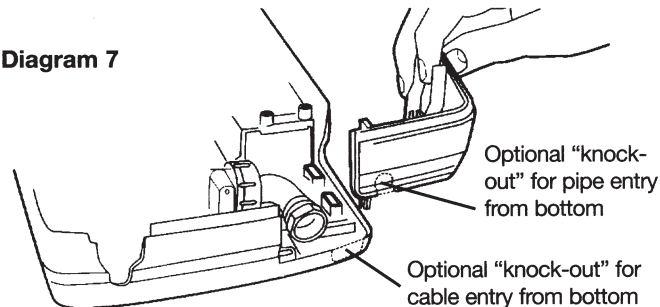

Diagram 7



7. If you have not done so remove the front cover (complete with knobs) of the unit by undoing the retaining screws at the top and bottom of the unit and lifting the cover off. Your shower is provided with two fixing positions in the backplate (see diagram 5). The top fixing hole is a key-hole slot (another key-hole is provided for alternative fixing), and should be marked and drilled first.

Tighten top screw with head protruding about 10mm from wall and hook the backplate over the screw head. This allows for correct and accurate alignment of your shower before marking and fixing the bottom position. You may not wish to tighten up both screws at this stage as the holes are elongated to allow for adjustment after other connections have taken place.

(b) Plumbing (See diagram 8)

The heater should be connected to the mains cold water supply. This must have a minimum running pressure of 69kPa (0,7 Bar, 10 p.s.i.) and a maximum pressure of 690kPa (7.0 Bar, 100 p.s.i.)

Before connecting the pipework of the shower ensure that pipework is flushed out.

1. It is recommended that WRAS listed isolating valve is fitted between the rising main and the unit. This will allow the unit to be serviced without turning off the cold water or exchanged without having to turn off the water at the water stop valve.
2. The heater can be fed from a header tank provided this has a minimum head of 7 metres (23ft).
3. 15mm copper or stainless steel pipe should be used. To avoid cross threading do not remove the brass nut from the elbow when positioning pipe.
In multiple shower installations correct pipework sizes should be calculated to maintain adequate flow to each shower
- 4a. If top entry is chosen, turn the elbow 180° into the required position.
- 4b. If rear entry is chosen, turn the elbow 180° and treat as top entry with the additional fitting of a "Yorkshire" elbow (soldered type) in the rear channel.

Diagram 8

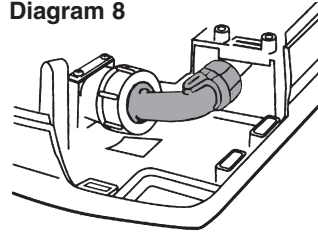

Top Entry or Rear Entry with addition of "Yorkshire" elbow (see note 5b)

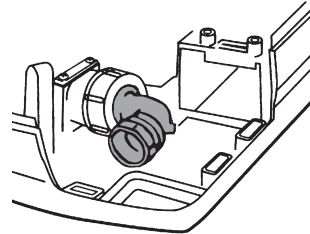

Bottom Entry

5. It is in order to use a WRAS (Water Regulations Advisory Scheme) approved sealant sparingly whilst avoiding excess finding its way into shower operating parts.
6. With stop valve connected, **flush the pipework through to remove particles etc**, before making the final connection to the shower. Blockage in the waterways (particularly the spray plate and solenoid valve) will prevent the heater working properly.
7. The shower is designed to have an open outlet and should only be used with recommended fittings. Do not connect the handset until after the shower front cover and corner section are fitted.

**WARNING: DO NOT FIT A TAP ON THE SHOWER OUTLET.
TAKE CARE TO AVOID RESTRICTING THE OUTLET OF THE
PRESSURE RELIEF DEVICE.**

(c) Electrical

The electrical installation must be in accordance with the current BS. 7671 (I.E.E. regulations).

- The shower is designed for a single phase A.C. electrical supply
Please check the rating plate on the unit to see what details apply to your unit

Rating	Cable sizes	Fuse / MCB	Cable length
7.2/6.6kW 240/230V	4mm ²	30A Cartridge fuse	17m Max
8.5/7.8kW 240/230V	6mm ²	40A Cartridge fuse	14m Max
		Type A MCB	22m Max
9.5/8.7kW 240/230V	10mm ²	40 or 45A Cartridge fuse	22m Max
	10mm ²	40 or 45A Cartridge fuse	22m Max

9.5/8.7kW version may be able to use 6mm² cable if Method 1 (clipped direct) is used.

Remember to uprate the cable if it runs in thermal insulation in a loft.

- In order to provide a means of isolation, the heater **MUST BE** permanently connected to the electricity supply through a double pole isolator switch with a gap of 3mm in each pole mounted in a convenient position. We recommend ceiling switches.
- Cut back cable as in diagram 9. Connect cable to terminal block making sure that all the retaining screws are **VERY tight** and that no cable insulation is trapped under the screws.

**WARNING: FAILURE TO COMPLY WITH THESE INSTRUCTIONS
COULD RESULT IN A FAILURE OF THE TERMINAL BLOCK.**

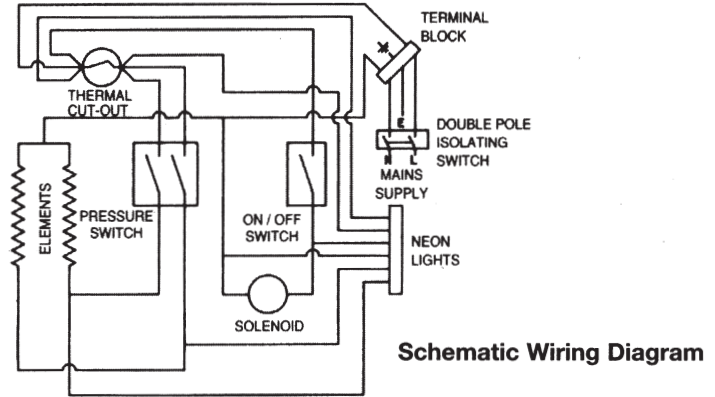

5. WARNING: THIS APPLIANCE MUST BE EARTHED

Diagram 9

- Fit the corner section back into the back plate.

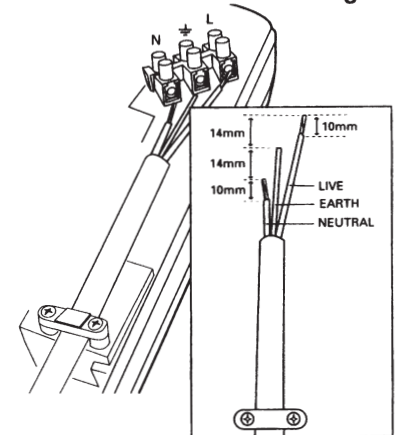
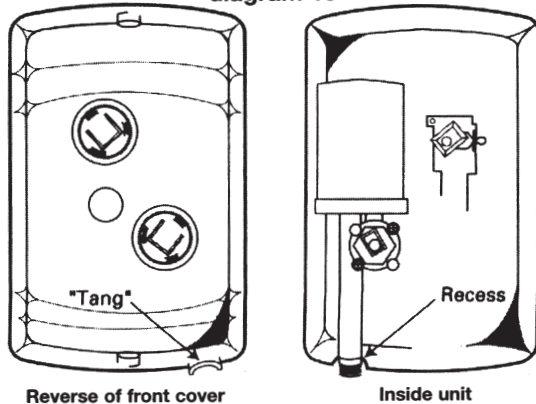

diagram 10



7. Fit the front cover back into position making sure the **knob is aligned correctly with the flow valve and power selector** (see diagram 10). Start by locating the “tang” around the recess for the outlet pipe, and then “roll” the front cover over the knobs and onto the top of the backplate. Secure with top and bottom screws”.
8. Operate the shower first without the handset to flush out particles, fit handset and then operate the shower as on page 2 and check:
 - (a) That the water gets to a satisfactory temperature.
 - (b) Water flow can be adjusted by knob “C”.
 - (c) Power selection does give a change in water temperature and power lights illuminate.
 - (d) Check again for leaks.
 - (e) That the holes in the handset are not blocked.
9. DEMONSTRATE OPERATION TO USER.

How to Maintain your “Aqua-Plus” Shower

It is recommended that the shower unit and accessories are cleaned using a soft cloth.

DO NOT use powerful abrasive or solvent cleaning fluids. It is advisable to switch off the shower at the isolating switch to avoid the shower accidentally switching on.

IN ORDER TO MAINTAIN THE PERFORMANCE OF YOUR SHOWER YOU MUST CLEAN THE SPRAYHEAD

All water contains particles of lime which build up in the sprayhead and unit reducing the performance. It is therefore important to clean the sprayhead by regularly dipping it in a suitable descaling solution. The frequency of this will vary from weekly to quarterly depending on water hardness and experience.

Additional Accessories

	Short Code	Model Code
Shower Control Lever (Interchangeable with Inner Control Knob for the elderly or less abled)		0725

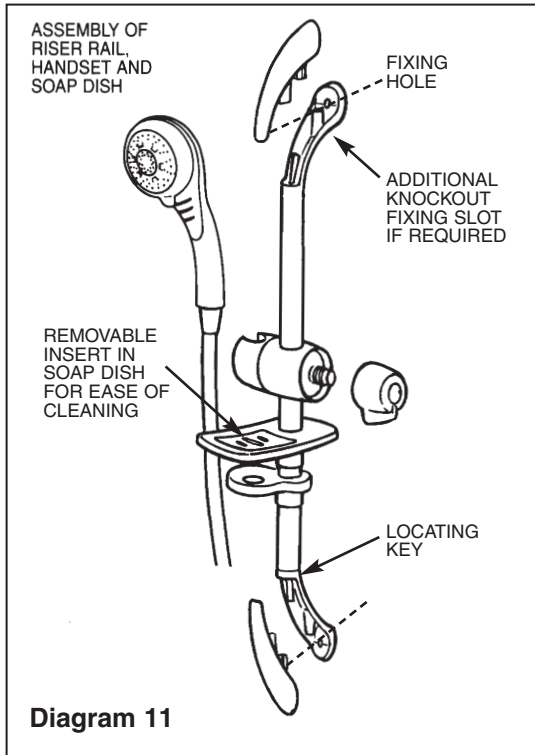

GUARANTEE

We, Heatstore Limited, guarantee that should this instant water heater prove to be defective by reason of faulty workmanship or material within 24 months of the date of purchase or commencement of hire purchase we will replace the defective parts **FREE OF CHARGE** on the condition that:-

- a) The appliance has been correctly installed and used only on the supply circuit or voltage stamped on the rating plate.
- b) The appliance has been used in accordance with these instructions and has not been tampered with or otherwise subject to misuse, neglect or accident.
- c) The appliance has not been taken apart, modified or repaired except by a person authorised by us.
- d) **EVIDENCE** of the date of purchase in the form of an invoice, receipt (hire purchase documents) is included with the appliance if returned under guarantee.

HEATSTORE

HEATSTORE LIMITED

Island Park, Bristow Broadway, Bristol BS11 9FB

Website: www.heatstore.co.uk

559-2031-11A